



USER MANUAL



MIRAGE 3000

LAWNMOWER



**BEFORE OPERATING THIS APPLIANCE
PLEASE READ THESE INSTRUCTIONS CAREFULLY**

Disclaimer: Due to constant upgradation, features and specifications are subject to change without notice

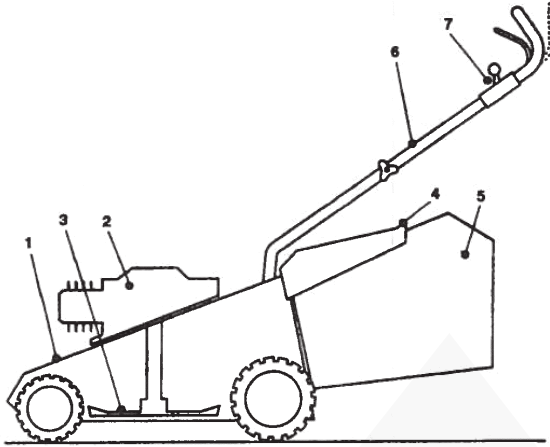

1. Chassis
2. Motor
3. Blade
4. Stone Deflector
5. Grass Catcher
6. Handle
7. Throttle control

INSTRUCTION LABEL

DO NOT OPERATE WITHOUT EITHER STONE GUARD OR GRASS CATCHER IN PLACE



Important : Read the instruction handbook before using the machine



Warning: Remove the spark plug and read instructions before carrying out any repair or maintenance



Danger of Cutting yourself. Blades in movement. Do not put hands or feet near or under the opening of the cutting plate



Danger of thrown of object. keep other people at a safe distance whilst working

ROUTINE MAINTENANCE

After work has been carried out on blade, reassemble as shown in the drawing, tightening the central screw (1) to 4 - 4.5 kgm

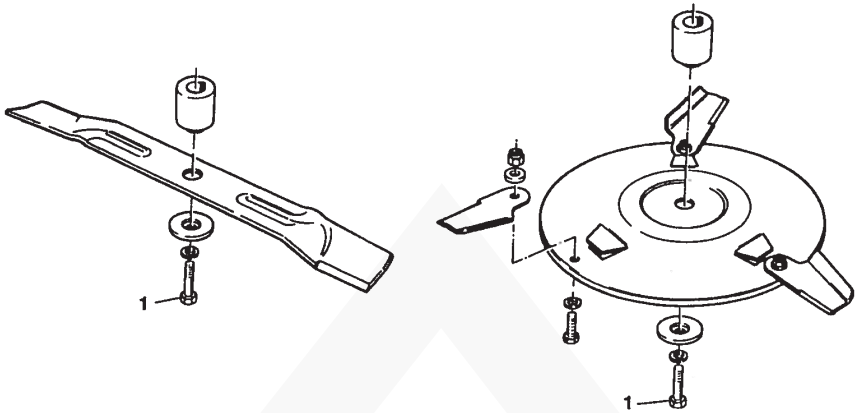

Check the oil level and top up as per the instructions in the engine handbook. Oil the wheel axles. Store the lawnmower in a dry place.

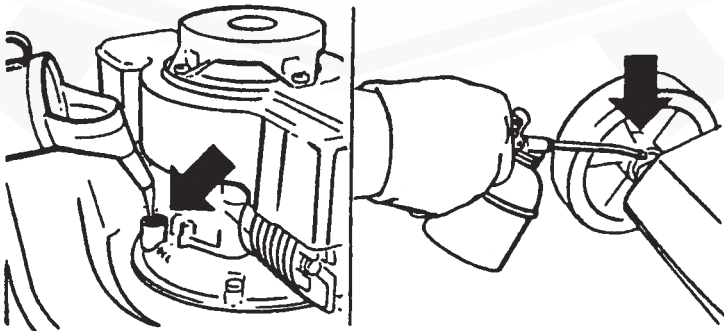

IMPORTANT: Before starting the engine for the first time, carefully read instructions as set out in the engine handbook

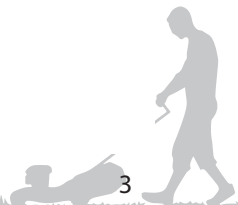

GRASS CUTTING

The lawn's appearance will be improved if it is always cut to the same height and is cut in alternate directions.

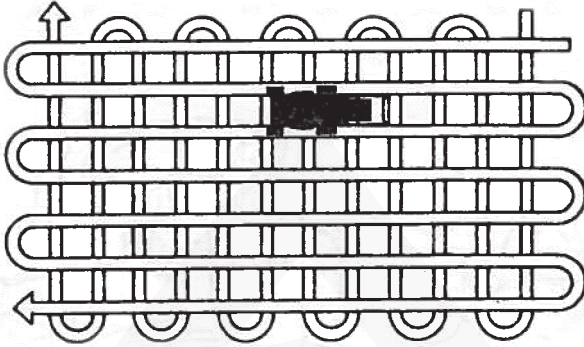

Once cutting is finished, wait for the blade to stop before carrying out any type of work on the machine.

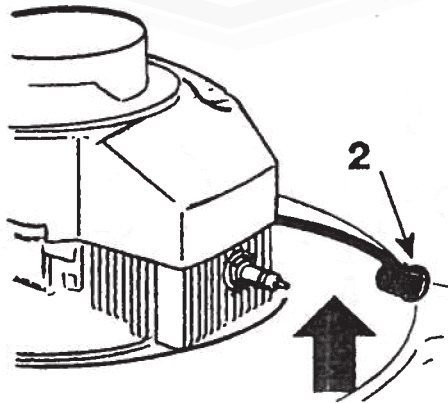

SAFETY REGULATIONS

TO BE FOLLOWED CAREFULLY

A) TRAINING

- 1) Read the instructions carefully. Be familiar with the controls and the proper use of the equipment. Learn how to stop the engine quickly.
- 2) Only use the lawnmower for the purpose for which it was made, that is, the cutting and collection of grass. Any other use can be dangerous and result in damage to the machine.
- 3) Never allow children or people unfamiliar with these instructions to use the lawnmower. Local regulations may restrict the age of the operator.
- 4) Never use the lawnmower:
 - When people, especially children, or pets are nearby;
 - If the operator has taken medicine or substances that can affect his ability to react and concentrate.
- 5) Keep in mind that the operator or user is responsible for accidents or hazards occurring to other people or their property.

B) PREPARATION

- 1) While mowing, always wear substantial footwear and long trousers. Do not operate the equipment when barefoot or wearing open sandals.
- 2) Thoroughly inspect the area where the equipment is to be used and remove all objects which may be thrown by the machine (stones, sticks, metal wire, bones, etc.).
- 3) **WARNING: DANGER!** Engine fuel is highly flammable!
 - Store fuel in containers specifically designed for this purpose.
 - Refuel using a funnel and outdoors only. Do not smoke while refuelling or whenever handling the fuel.
 - Add fuel before starting the engine. Never remove the cap of the fuel tank or add fuel while the engine is running or when the engine is hot.
 - If fuel is spilled, do not attempt to start the engine but move the machine away from the area of spillage and avoid creating any source of ignition until the fuel has evaporated and the vapour dispersed.
 - Replace all fuel tanks and containers caps securely.
- 4) Substitute faulty silencers.
- 5) Before using, always carry out an overall visual inspection, particularly of the blade, seeing that the screws and cutter assembly are not worn or damaged. Replace worn or damaged blades and screws in sets to preserve balance.
- 6) Before mowing, attach the discharge opening guards (grass catcher or deflector).

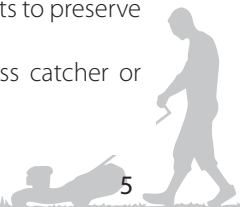

C) OPERATION

- 1) Do not operate the engine in a confined space where dangerous carbon monoxide fumes can collect.
- 2) Mow only in daylight or good artificial light.
- 3) Avoid operating the equipment in wet grass or when raining.
- 4) Always be sure of your footing on slopes.
- 5) Walk, never run and do not allow yourself to be pulled along by the lawnmower.
- 6) Mow across the face of slopes, never up and down.
- 7) Exercise extreme caution when changing direction on slopes.
- 6) Do not mow on slopes of more than 20°.
- 9) Exercise extreme caution when pulling the lawnmower towards you.
- 10) Stop the blade if the lawnmower has to be tilted for transportation when crossing surfaces other than grass, and when transporting the lawnmower to and from the area to be mowed.
- 11) Never operate the lawnmower with defective guards, or without safety devices, for example deflectors and/or grass catchers, in place.
- 12) Do not change the engine governor settings or over speed the engine.
- 13) On those models with drive traction, disengage the drive clutch before starting the engine.
- 14) Start the engine or start the motor carefully according to instructions and with feet well away from the blade.
- 15) Do not tilt the lawnmower when starting the engine or switching on the motor. Start the engine or motor on a flat surface that is free of obstacles and tall grass.
- 16) Do not put hands or feet near or under rotating parts. Keep clear of the discharge opening at all times.
- 17) Never pick up or carry a lawnmower while the engine is running.
- 18) Stop the engine and disconnect the spark plug wire:
 - Before carrying out any work beneath the cutting deck or unclogging the chute;
 - Before checking, cleaning or working on the lawnmower;
 - After striking a foreign object. Inspect the lawnmower for damage and make repairs before restarting and operating the lawnmower;
 - If the lawnmower starts to vibrate abnormally (immediately check and remove the cause of the vibration);
- 19) Stop the engine:
 - Whenever you leave the lawnmower unattended. Remove the key from those models having electric starters. Before refuelling.

- Every time the grass catcher is removed or replaced.
- 20) Reduce the throttle setting during engine shut down and turn the fuel off at the conclusion of mowing, following the instructions contained in the engine handbook.
 - 21) When mowing always keep a safe distance from the rotating blade. This distance is the length of the handle.

D) MAINTENANCE AND STORAGE

- 1) Keep all nuts, bolts and screws tight to be sure the equipment is in safe working condition. Regular maintenance is essential for safety and for maintaining performance levels.
- 2) Never store the equipment with fuel in the tank inside a building where vapour may reach a flame or a spark or a source of extreme heat.
- 3) Allow the engine to cool before storing in an enclosed space.
- 4) To reduce the fire hazard, keep the engine, exhaust silencer, battery compartment and fuel storage area free of grass, leaves, or excessive grease. Do not leave garden rubbish containers within a room.
- 5) Check the deflector and grass catcher frequently for wear or deterioration.
- 6) For reasons of safety, do not use the equipment with worn or damaged parts. Parts are to be replaced and not repaired. Use genuine spare parts (blades should always bear the symbol (M)). Parts which are not of an equivalent quality can damage the equipment and be dangerous for your safety.
- 7) If fuel tank has to be drained, this should be done outdoors and when the engine is cool.
- 8) Wear strong work gloves when removing and reassembling the blade.
- 9) Check the blade's balance after sharpening.

Should you have any doubts or problems, do not hesitate to contact the nearest Service Centre or your Sales outlet.

ASSEMBLY

Your Mirage mower is packed partially assembled for convenience of storage and handling. All that you are required to do is assemble the handle and should it be required, the grassbox.

GRASSBOX ASSEMBLY

Push the bottom half of the grassbox into the groove of the top half of the grassbox and secure the two halves with the bolts and nuts provided. (Some grassboxes clip together without bolts).

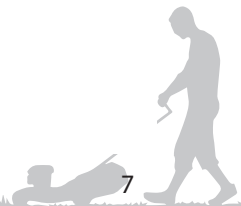



FITIING THE GRASS CATCHER

To fit the grassbox simply raise the rear safety flap using the handle provided. Insert the lower lip of the grassbox into the aperture. Tilt the grassbox forward and allow the lip of the safety flap to latch onto the lip at the top of the grassbox.

To remove the grassbox simply raise the safety flap and lift the grassbox out.

HANDLE ASSEMBLY

(For domestic and utility models only)

Assemble the top and bottom halves of the handle using the bolts and plastic knobs provided. Tighten the knobs so as to secure the handle firmly. The knobs will be on the inside of the lower handle.

CUTTING HEIGHT ADJUSTMENT

The height adjustment lever is situated near the right rear wheel of the mower. To adjust the height, disengage the lever from the ratchet and move to the desired position. For safety this adjustment is best done with the engine switched off. Do not bend the lever further than absolutely necessary as this may result in premature failure of the spring.

FOR PETROL ENGINE MACHINES

BEFORE STARTING

1. Check the instructions in the engine manufacturer's handbook.
2. On petrol engined machines, check that the engine oil level is correct and that the correct petrol requirement has been poured into the tank.

TO START THE ENGINE

1. Set the cutting height so as to prevent obstruction to the cutting blades.
2. Set the throttle control to the "start" position.
3. Pull the starter cord. Once the machine has started, move the throttle to the "run" position.
4. Allow the engine to warm up before putting it under load.

TO STOP THE ENGINE

1. Set the throttle to the "stop" position.
2. Certain petrol engines are fitted with a stop button which must be depressed in order to stop the engine.

ALRITE MIRAGE 3000 LAWN MOWER DIAGRAM & SPARE LIST

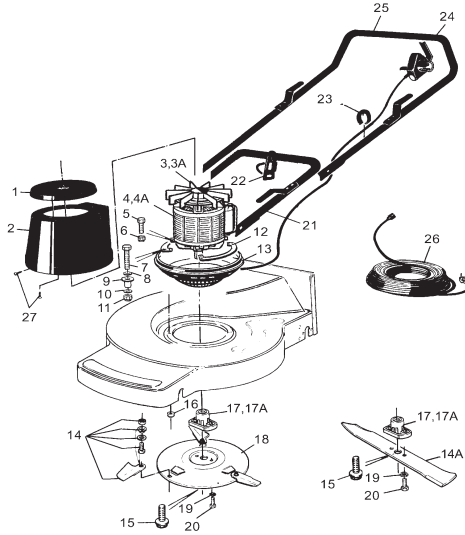

Part No	DESCRIPTION
1	LID MOTOR COVER
2	COVER MOTOR
3A	FAN - ATB
3B	FAN - FEMCO
4	2200W MOTOR (GREEN BOSS)
4A	2600W MOTOR (GREEN BOSS)
5	COVER MOTOR BOTTOM
6	NUT
7	BOLT
8	BUSH SET
9	BUSH SET
11	NUT
12	MOTOR BRACKET -STEEL
13	BASKET
14	BLADE SET -TURBO

Part No	DESCRIPTION
14A	BLADE - BAR
15	BOLT - ELECTRIC
17	BOSS GREEN
17A	BOSS YELLOW
18	CUTTING DISC
19	WASHER
20	SCREW
21	LOWER HANDLE
22	CABLE HOOK
23	CLAMP
24	SWITCH
25	HANDLE
26	CABLE 25M - 2200W
26A	CABLE 25M - 2600W
27	SCREW

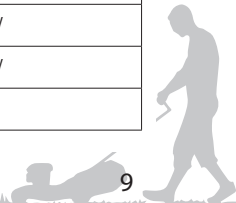

INSPECTION & MAINTENANCE

For safety use, make sure a three-month clean the machine. Before working, make sure inspect the filter and the nozzle, make sure there is no impurity. After working, make sure there is no water in the pump and the hose.

If the machine need to be repaired in the guarantee period, please return the machine to the shop. You need to provide the certificate of purchase in order to repair or get the substitute.

Before Packaging, The machine should be cleaned, then use closed packaging, packaging should be firm. Storage the machine in dry.

For transportation safety. The machine should comply with ISTA.



Meaning of crossed –out wheeled dustbin:

Do not dispose of electrical machines as unsorted municipal waste, use separate collection facilities.

Contact you local government for information regarding the collection systems available.

If electrical machines are disposed of in landfills or dumps, hazardous substances can leak into the groundwater and get into the food chain, damaging your health and well-being.

When replacing old machines with new ones, the retailer is legally obligated to take back your old machine for disposals at least free of charge.

Warranty Card CUSTOMER COPY



Purchaser's Name & Address

Product Name

Alrite Mirage 3000 Lawn Mower

Product Serial No.

Invoice / DN No.

Date of Delivery

Dealer's Office Seal

Dealer Sign _____

Customer Sign. _____

I/We accept the terms and conditions of Warranty as in the Warranty Card.

Warranty Card DEALER'S COPY



Purchaser's Name & Address

Product Name

Alrite Mirage 3000 Lawn Mower

Product Serial No.

Invoice / DN No.

Date of Delivery

Dealer's Office Seal

Dealer Sign _____

Customer Sign. _____

I/We accept the terms and conditions of Warranty as in the Warranty Card.

Warranty Card COMPANY COPY



Purchaser's Name & Address

Product Name

Alrite Mirage 3000 Lawn Mower

Product Serial No.

Invoice / DN No.

Date of Delivery

Dealer's Office Seal

Dealer Sign _____

Customer Sign. _____

I/We accept the terms and conditions of Warranty as in the Warranty Card.



1. **LIMITED WARRANTY PERIOD** : For a period of six months from the date of Sale / delivery of the product which ever is earlier. 2. **LIMITED WARRANTY OBLIGATION** : Replacement of defective part(s) by authorized dealer are free of charges. If found defective by reasons of defective material / poor workmanship, parts will be replaced and there will be no value re-imbusement. 3. **TERMS & CONDITIONS** : a. Claims under warranty will be accepted on submission of Warranty Card duly filled and stamped by authorized dealer together with the original purchase document. : b. Shipping / transportation / Incidental charges incurred in replacing defective parts under warranty shall be borne by the purchaser.

WARRANTY null & void if

- (i) Lack of maintenance, (ii) Incorrect use of the machine or tampering, (iii) Use of non-genuine spare parts, (iv) Usage of acids, solvents, or any flammable materials, (v) Non-usage of filter water / clear water / soft water & using water above 40°C temperature, (vi) While using the pressure washers to draw water which is contaminated with dust & solvents (eg. paint thinners, gasoline, oil, etc.), (vii) Repair done by unauthorized service people, (viii) Those parts subject to wear & tear due to normal operations and plastic parts, rubber items etc, (ix) Loose connections, faulty electrical fixtures & fluctuations in power supply.
4. Should any failure occur during or after the warranty period, customer does not have the right to interrupt payment / price discount.
5. Incidental or consequential damages like inconvenience commercial loss, loss of tie, mental agony etc.
6. Loss of any nature due to operation or non-operation is not covered under warranty.
7. All free service are at Dealer's service point only.
8. Warranty ceases if service is not done periodically.
9. The attached card should be completed and returned to Ratnagiri Impex Pvt. Ltd. for registration immediately after sale / delivery.
10. The warranty is void unless you register the warranty card with Ratnagiri Impex Pvt. Ltd.
11. The decision of Ratnagiri Impex Pvt. Ltd., in settling the warranty is final in all respects.
12. All disputes are subject to Bangalore Courts Jurisdiction

1. **LIMITED WARRANTY PERIOD** : For a period of six months from the date of Sale / delivery of the product which ever is earlier. 2. **LIMITED WARRANTY OBLIGATION** : Replacement of defective part(s) by authorized dealer are free of charges. If found defective by reasons of defective material / poor workmanship, parts will be replaced and there will be no value re-imbusement. 3. **TERMS & CONDITIONS** : a. Claims under warranty will be accepted on submission of Warranty Card duly filled and stamped by authorized dealer together with the original purchase document. : b. Shipping / transportation / Incidental charges incurred in replacing defective parts under warranty shall be borne by the purchaser.

WARRANTY null & void if

- (i) Lack of maintenance, (ii) Incorrect use of the machine or tampering, (iii) Use of non-genuine spare parts, (iv) Usage of acids, solvents, or any flammable materials, (v) Non-usage of filter water / clear water / soft water & using water above 40°C temperature, (vi) While using the pressure washers to draw water which is contaminated with dust & solvents (eg. paint thinners, gasoline, oil, etc.), (vii) Repair done by unauthorized service people, (viii) Those parts subject to wear & tear due to normal operations and plastic parts, rubber items etc, (ix) Loose connections, faulty electrical fixtures & fluctuations in power supply.
4. Should any failure occur during or after the warranty period, customer does not have the right to interrupt payment / price discount.
5. Incidental or consequential damages like inconvenience commercial loss, loss of tie, mental agony etc.
6. Loss of any nature due to operation or non-operation is not covered under warranty.
7. All free service are at Dealer's service point only.
8. Warranty ceases if service is not done periodically.
9. The attached card should be completed and returned to Ratnagiri Impex Pvt. Ltd. for registration immediately after sale / delivery.
10. The warranty is void unless you register the warranty card with Ratnagiri Impex Pvt. Ltd.
11. The decision of Ratnagiri Impex Pvt. Ltd., in settling the warranty is final in all respects.
12. All disputes are subject to Bangalore Courts Jurisdiction

1. **LIMITED WARRANTY PERIOD** : For a period of six months from the date of Sale / delivery of the product which ever is earlier. 2. **LIMITED WARRANTY OBLIGATION** : Replacement of defective part(s) by authorized dealer are free of charges. If found defective by reasons of defective material / poor workmanship, parts will be replaced and there will be no value re-imbusement. 3. **TERMS & CONDITIONS** : a. Claims under warranty will be accepted on submission of Warranty Card duly filled and stamped by authorized dealer together with the original purchase document. : b. Shipping / transportation / Incidental charges incurred in replacing defective parts under warranty shall be borne by the purchaser.

WARRANTY null & void if

- (i) Lack of maintenance, (ii) Incorrect use of the machine or tampering, (iii) Use of non-genuine spare parts, (iv) Usage of acids, solvents, or any flammable materials, (v) Non-usage of filter water / clear water / soft water & using water above 40°C temperature, (vi) While using the pressure washers to draw water which is contaminated with dust & solvents (eg. paint thinners, gasoline, oil, etc.), (vii) Repair done by unauthorized service people, (viii) Those parts subject to wear & tear due to normal operations and plastic parts, rubber items etc, (ix) Loose connections, faulty electrical fixtures & fluctuations in power supply.
4. Should any failure occur during or after the warranty period, customer does not have the right to interrupt payment / price discount.
5. Incidental or consequential damages like inconvenience commercial loss, loss of tie, mental agony etc.
6. Loss of any nature due to operation or non-operation is not covered under warranty.
7. All free service are at Dealer's service point only.
8. Warranty ceases if service is not done periodically.
9. The attached card should be completed and returned to Ratnagiri Impex Pvt. Ltd. for registration immediately after sale / delivery.
10. The warranty is void unless you register the warranty card with Ratnagiri Impex Pvt. Ltd.
11. The decision of Ratnagiri Impex Pvt. Ltd., in settling the warranty is final in all respects.
12. All disputes are subject to Bangalore Courts Jurisdiction



1st Free Service Coupon

ISO 9001-2008
CERTIFIED COMPANY

FREE SERVICE COUPON (30 Days / 20 hrs (Which ever is earlier))

Model
Alrite Mirage 3000 Lawn Mower

Serial Number

PDI Date

Service No.

Purchase bill no. Date

Dealer's Office Seal & Signature

- Operations:
- Check and Test the Fuel Mixture.
 - Check and Clean the Air Filter
 - Check, Clean and Adjust the Spark plug
 - Check and Adjust the Carburetor Tuning
 - Check and Sharpen the cutting Tools
 - Start and Check the Noise, Vibration, Loosen / Fasteners etc.
 - Product familiarization on Usage
 - Routine maintenance and Storage

Customer Signature.....

Conditions: Operations listed have been performed to my entire satisfaction without any labour charges. Only consumables were charged.



agriculture | horticulture | sericulture | plantations | forestry | garden | health care

WARRANTY AND FREE SERVICE COUPON



2nd Free Service Coupon

ISO 9001-2008
CERTIFIED COMPANY

FREE SERVICE COUPON (30 Days / 20 hrs (Which ever is earlier))

Model
Alrite Mirage 3000 Lawn Mower

Serial Number

PDI Date

Service No.

Purchase bill no. Date

Dealer's Office Seal & Signature

- Operations:
- Check and Test the Fuel Mixture.
 - Check and Clean the Air Filter
 - Check, Clean and Adjust the Spark plug
 - Check and Adjust the Carburetor Tuning
 - Check and Sharpen the cutting Tools
 - Start and Check the Noise, Vibration, Loosen / Fasteners etc.
 - Product familiarization on Usage
 - Routine maintenance and Storage

Customer Signature.....

Conditions: Operations listed have been performed to my entire satisfaction without any labour charges. Only consumables were charged.



agriculture | horticulture | sericulture | plantations | forestry | garden | health care

WARRANTY AND FREE SERVICE COUPON



3rd Free Service Coupon

ISO 9001-2008
CERTIFIED COMPANY

FREE SERVICE COUPON (30 Days / 20 hrs (Which ever is earlier))

Model
Alrite Mirage 3000 Lawn Mower

Serial Number

PDI Date

Service No.

Purchase bill no. Date

Dealer's Office Seal & Signature

- Operations:
- Check and Test the Fuel Mixture.
 - Check and Clean the Air Filter
 - Check, Clean and Adjust the Spark plug
 - Check and Adjust the Carburetor Tuning
 - Check and Sharpen the cutting Tools
 - Start and Check the Noise, Vibration, Loosen / Fasteners etc.
 - Product familiarization on Usage
 - Routine maintenance and Storage

Customer Signature.....

Conditions: Operations listed have been performed to my entire satisfaction without any labour charges. Only consumables were charged.



agriculture | horticulture | sericulture | plantations | forestry | garden | health care

WARRANTY AND FREE SERVICE COUPON





Small Maintenance. Big Savings.

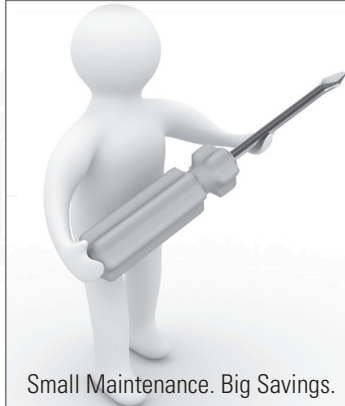

Small Maintenance. Big Savings.



Small Maintenance. Big Savings.



Do's & Don'ts

- Always read the instruction manual supplied along with the equipments and understand the correct installation and operating procedures before attempting to use the equipments.
- It is important to use the personal protection equipments such as head helmet with visor, ear defenders, goggles, safety gloves, cut resistant shoes, trousers and jackets while operating potentially dangerous machines.
- Avoid untrained persons using the equipments. Children must not be allowed to handle these equipments.
- Always use genuine spares and accessories in repairs and usage to derive maximum life of the equipments.
- Always keep the equipments in good working condition to minimise loss of output as well as to reduce the pollution and save the environment.
- Do not use the machine within range of persons unless they wear protective clothing.
- Do not operate the machine when fatigued or under the influence of alcohol or drugs.
- To reduce the risk of injury, close supervision is necessary when a machine is used near children. Equipment shall not be used by children or untrained person.
- Disconnect from the electrical power supply before carrying out user maintenance.

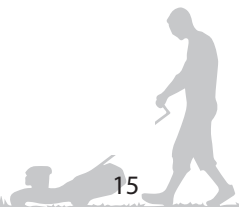

The Little Champion for Gardens. Heavy Duty Electrical Lawnmowers.



RATNAGIRI IMPEX PVT., LTD.,
Annapurna House, #1/1G, 7th Cross, New Guddadahalli
Mysore Road, Bangalore - 560 026
Customer Care: 1800-425-3036
Email: marketing@ratnagiriimpeex.com



Marketed by:
**ratnagiri
impeex**
BRINGING YOU THE FUTURE... NOW

www.ratnagiriimpeex.com

AN ISO 9001:2008 CERTIFIED COMPANY